

GasMultiBloc® Combined regulator and safety shut-off valves Single-stage function

DUNGS®
Combustion Controls

MB-D(LE) 403 B01

7.20



Technical description

The DUNGS GasMultiBloc® integrates filter, regulator, valves and pressure switches in one compact fitting.

- Dirt trap: microfilter
- One regulator and two main valves: B01
- Two valves are fast opening
- One valve is fast opening, one valve is slow opening
- Solenoid valves up to 200 mbar (20 kPa) as per DIN EN 161 Class A Group 2
- Sensitive setting of output pressure by proportional regulator as per DIN EN 88 Class A Group 2
- High flow rates with low pressure drop
- DC solenoid drive interference degree N
- Main volume restrictor at valve V2
- Hydraulic opening delay
- Flange connections with pipe threads as per ISO 7/1
- Simple mounting, compact, light-weight

The modular system permits individual solutions by using external ignition gas tap in connection with separately controlled valves, by adding a valve proving system, mini/maxi pressure switches, pressure limiters, partial volume setting by closing stroke limiter at valve V2 and regulator blocking for liquid gas applications.

Application

The modular system permits individual solutions in gas safety and regulator engineering. Suitable for gases of families 1, 2, 3 and other neutral gaseous media.

Approvals

EC type testing certificate as per:

- EC-Gas Appliances Regulation
- Approvals in other important gas consuming countries.

Functional description of gas flow

1. When the valves V1 and V2 are closed, chamber A is under inlet pressure.
2. A hole D in the filter housing connects min. pressure switch with chamber A. If the inlet pressure applied to the pressure switch exceeds the incoming reference value, it switches through to the automatic burner control.
3. After release by the automatic burner control, valves V1 and V2 open. The gas flows through chambers A, B and C of the GasMultiBloc.

Operating method of valve-regulator combination on valve V1

A regulator, compensating for residual pressure is integrated in valve V1 (pressure regulating part). Armature 7 is not connected to valve plate unit 3. When it opens, armature 7 pretensions compression spring (V1) 5 and releases the valve plate unit. When the valve closes, the armature acts directly on the valve plate unit. The output pressure upstream of valve V2 is defined by pretensioning regulating spring 8 (tension spring) via setting screw 16. The output pressure acts via opening E on the working diaphragm of regulator part 1. In regulated state, setting spring inlet pressure and pressure of working diaphragm are in force equilibrium.

Sectional drawing of MB-DLE...

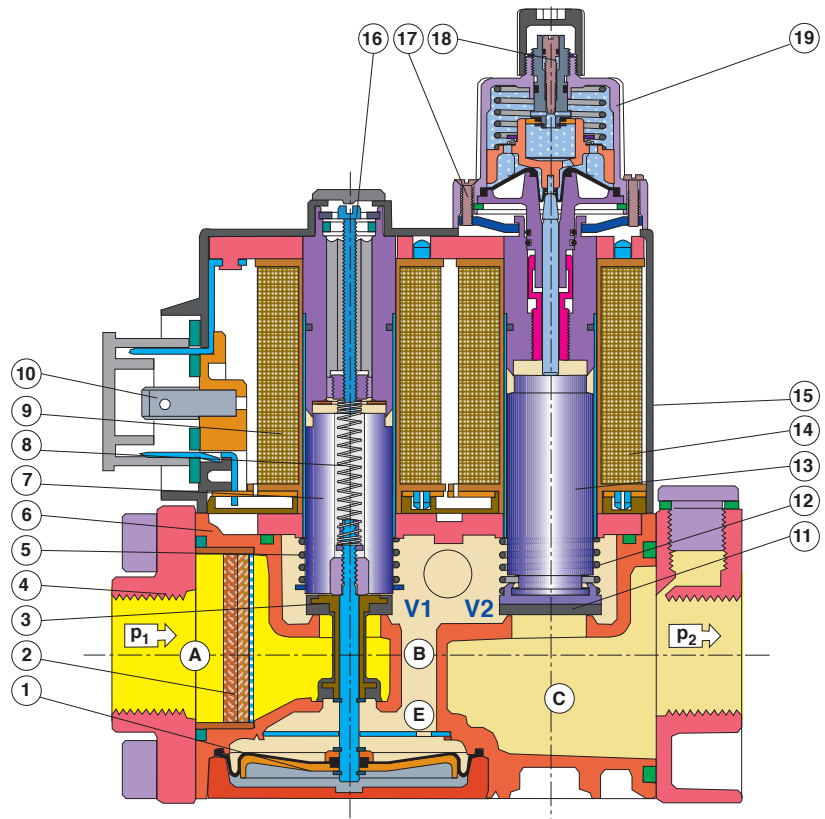

1	Pressure regulator	8	Regulating spring	15	Solenoid housing
2	Microfilter	9	Solenoid V1		Setting:
3	Valve V1	10	Electrical connection	16	- Gas pressure p_a
4	Connection flange	11	Valve V2	17	- Main volume
5	Closing spring V1	12	Closing spring V2	18	- Fast stroke
6	Housing	13	Armature V2	19	Hydraulic brake
7	Armature V1	14	Solenoid V2		

Operating method of valve V2

Armature 13 of valve V2 is connected to valve plate unit 11. When it opens, armature 13 pretensions closing spring 12. The maximum valve opening can be set by limiting the armature stroke by means of the main volume restrictor 17.

Min. opening (residual stroke) of valve (0.5 to 1.0 mm)

Main volume restrictor 17 is set by rotating the adjusting plate or the hydraulic brake 19. The fast and/or slow opening characteristic is influenced by setting the fast stroke 18 at the hydraulic brake 19 under the cover.

Closing function

When the supply voltage to the solenoid coils of valves V1 and V2 is interrupted, they are closed within < 1 s by the compression springs.

Closing stroke limitation (option)

A partial volume setting is possible by means of a closing stroke limiter. Valve V2 becomes a regulating actuator without zero shutoff. Partial volume and main volume are adjustable.

Pressure taps

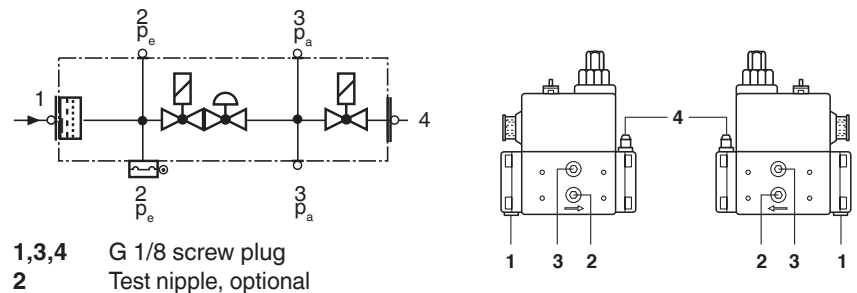

Electrical connection

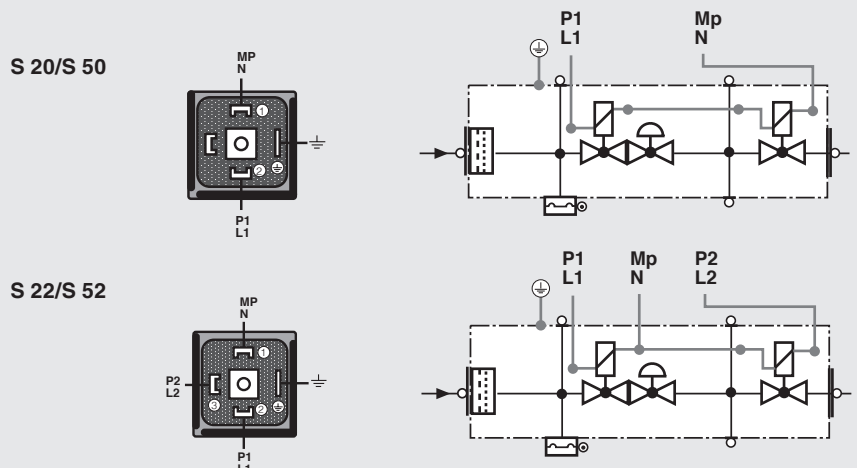

Specifications

Nominal diameters Flange with pipe threads as per ISO 7/1 (DIN 2999)	MB-...403 B01 Rp 3/8, 1/2 and their combinations																				
Max. operating pressure	MB-...403 $p_{max.} = 200 \text{ mbar (20 kPa)}$																				
Output pressure ranges	MB-...403 B01 S20/S22 $p_a : 4 \text{ mbar (0.4 kPa) to 20 mbar (2 kPa)}$ MB-...403 B01 S50/S52 $p_a : 4 \text{ mbar (0.4 kPa) to 50 mbar (5 kPa)}$																				
Media	Gases of families 1, 2, 3 and other neutral gaseous media																				
Ambient temperature	-15°C to +70°C (Do not operate MB-D below 0°C in liquid gas systems. Only suitable for gaseous liquid gas, liquid hydrocarbons destroy sealing materials.)																				
Dirt trap	Sieve with 0.8 mm mesh width, filter made of random laid nonwoven fabric, micro-filter, two-layer, changing the filter is possible by removing the valve.																				
Pressure switches	Types GW A5, GW A2, NB A2, ÜB A2 mountable as per DIN EN 1854. For further information, refer to Datasheet GW A2 No. 215 183 and Datasheet GW A5 No. 225 901.																				
Pressure regulator	Pressure regulator compensated for residual pressure, leakproof seal when switched off by means of valve V1 as per DIN EN 88 Class A. Setpoint spring permanently installed (no spring exchange possible). A vent line above roof is not required. Internal pulse tap provided.																				
Solenoid valve V1	Valve as per DIN EN 161 Class A Group 2, fast closing, fast opening																				
Solenoid valve V2	Valve as per DIN EN 161 Class A Group 2																				
	<table border="1"> <thead> <tr> <th></th> <th colspan="2">Valve V2 design</th> <th>Main volume restrictor</th> </tr> </thead> <tbody> <tr> <td>MB</td> <td>fast closing</td> <td>fast opening</td> <td>without</td> </tr> <tr> <td>MB-D</td> <td>fast closing</td> <td>fast opening</td> <td>with</td> </tr> <tr> <td>MB-DLE</td> <td>fast closing</td> <td>slow opening</td> <td>with</td> </tr> <tr> <td>MB-LE</td> <td>fast closing</td> <td>slow opening</td> <td>without</td> </tr> </tbody> </table>		Valve V2 design		Main volume restrictor	MB	fast closing	fast opening	without	MB-D	fast closing	fast opening	with	MB-DLE	fast closing	slow opening	with	MB-LE	fast closing	slow opening	without
	Valve V2 design		Main volume restrictor																		
MB	fast closing	fast opening	without																		
MB-D	fast closing	fast opening	with																		
MB-DLE	fast closing	slow opening	with																		
MB-LE	fast closing	slow opening	without																		
Measuring/ignition gas connection	For G 1/8 as per DIN ISO 228, refer to Pressure taps on page 2																				
Voltage / frequency	50-60 Hz, 220 - 230 V AC, -15% +10%																				
Electrical connection	Plug connection as per DIN EN 175301-803 for valves and pressure switches																				
Rating/power consumption	Refer to Dimensions on page 5																				
Switch-on duration	100%																				
Degree of protection	IP 54 as per IEC 529 (EN 60529)																				
Radio interference	Interference degree N																				
Materials of gas conveying parts	Housing aluminium die casting Diaphragms, seals NBR basis, Silopren (silicone rubber) Solenoid drive steel, brass, aluminium																				
Installation position	Solenoid vertically upright or lying horizontally as well as its intermediate positions.																				

Equipment variants GasMultiBloc®...B01 Single-stage function	403 B01	
MB	•	
MB-D	•	
MB-DLE	•	
MB-LE	•	
Microfilter (standard) with sieve	•	
Gas pressure switch downstream of filter	•	
Pressure regulator	•	
Valve V1, double seat	•	
Valve V2, single seat	•	
Closing stroke limitation	(•)	V2 becomes an actuator without shutoff
Valves opening together	•	S 20
Valves opening separately	(•)	S 22
Flange Rp 3/8 Rp 1/2	• •	• = possible (•) = on request - = not possible

MB-...B01 version

- V1 = Valve 1
- V2 = Valve 2
- 3 = Filter
- 4 = Pressure switch
- 5 = Regulator

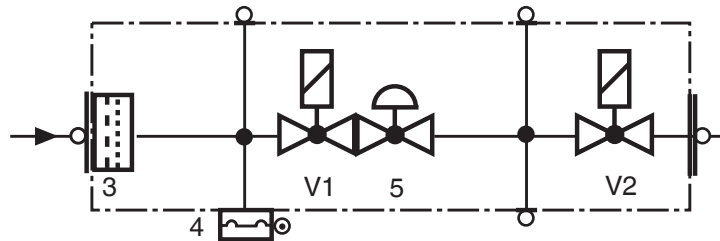

Mounting of VPS 504 valve proving system possible

Type key of MultiBloc®

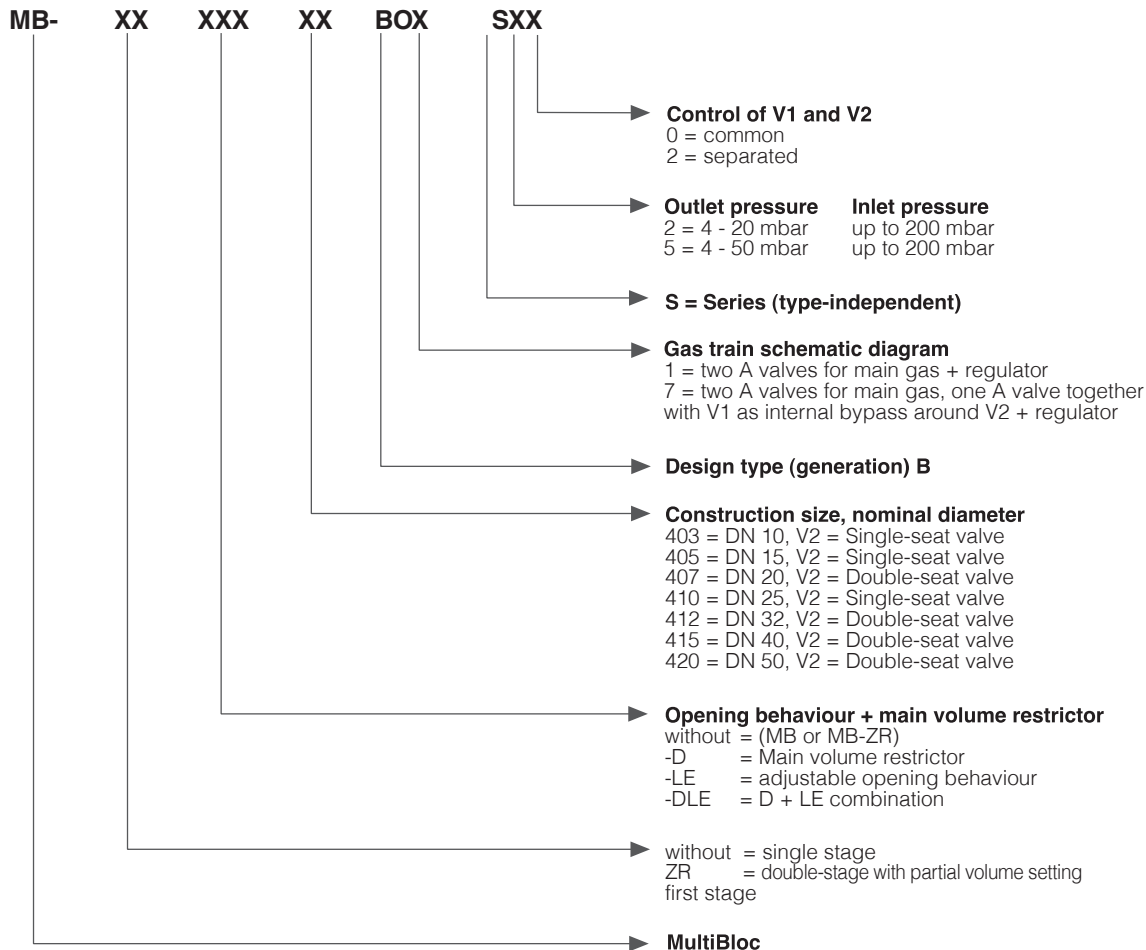

Dimensions [mm]

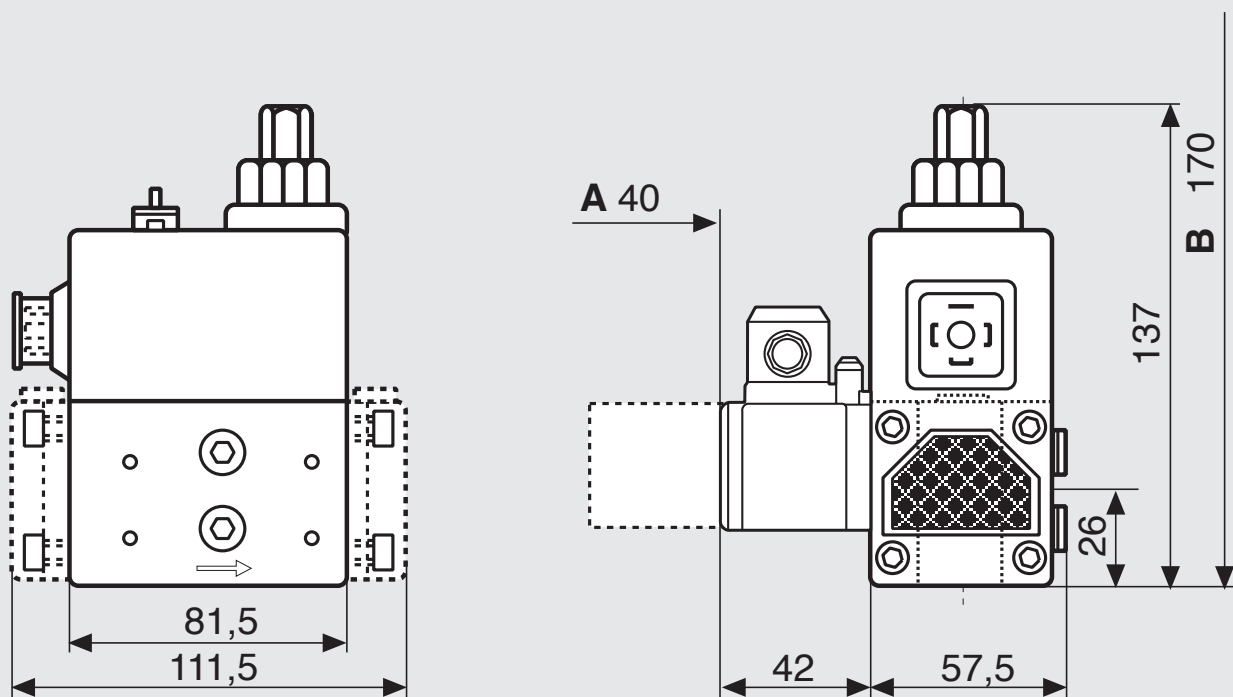

A = Space requirement for opening the cover of pressure switch

B = Space requirement for exchanging the solenoid

Type	Rp	Opening time	Weight [kg]
MB-D 403 B01	Rp 1/2	< 1 s	1.4
MB-DLE 403 B01	Rp 1/2	< 20 s	1.5

Rating / power consumption

[VA] 230 V AC; +20°C

MB...403 B01 S 20	24
MB...403 B01 S 22	36

GasMultiBloc®
Combined regulator and
safety shut-off valves
Single-stage function

MB-D(LE) 403 B01



Volumetric flow pressure loss characteristics in regulated state with microfilter

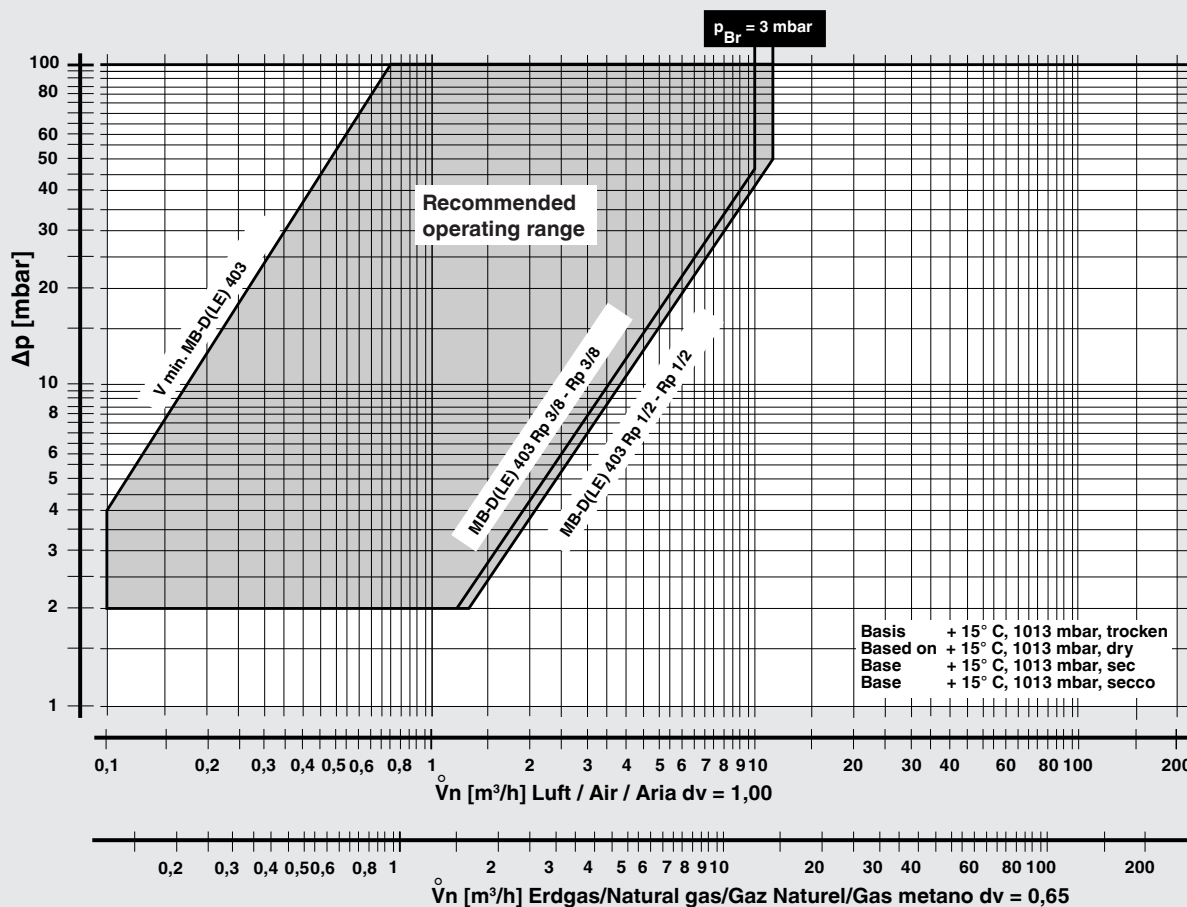

$f = \sqrt{\frac{\text{Dichte Luft}}{\text{Dichte des verwendeten Gases}}}$
 Spec. weight air / Spec. weight of gas used
 poids spécifique de l'air / poids spécifique du gaz utilisé
 peso específico aria / peso específico del gas utilizado

Gas type	Density [kg/m³]	dv	f
Nat. gas	0.81	0.65	1.24
City gas	0.58	0.47	1.46
LPG	2.08	1.67	0.77
Air	1.24	1.00	1.00

$\dot{V}_{\text{verwendetes Gas/gas used/gaz utilisé/gas utilizzato}} = \dot{V}_{\text{Luft/air/air/aria}} \times f$

We reserve the right to make any changes in the interest of technical progress.

Head Offices and Factory
Karl Dungs GmbH & Co. KG
Karl-Dungs-Platz 1
D-73660 Urbach, Germany
Telephone +49 (0)7181-804-0
Fax +49 (0)7181-804-166

Postal address
Karl Dungs GmbH & Co. KG
Postfach 12 29
D-73602 Schorndorf, Germany
e-mail info@dungs.com
Internet www.dungs.com